

Šola Optike

24. November 2011, A. Z. Žagar

vsebina



1. Optična vlakna
2. Kabli z optičnimi vlakni
3. Standardi
4. FTTH in PON tehnologije
5. Pretvorniki



optična vlakna

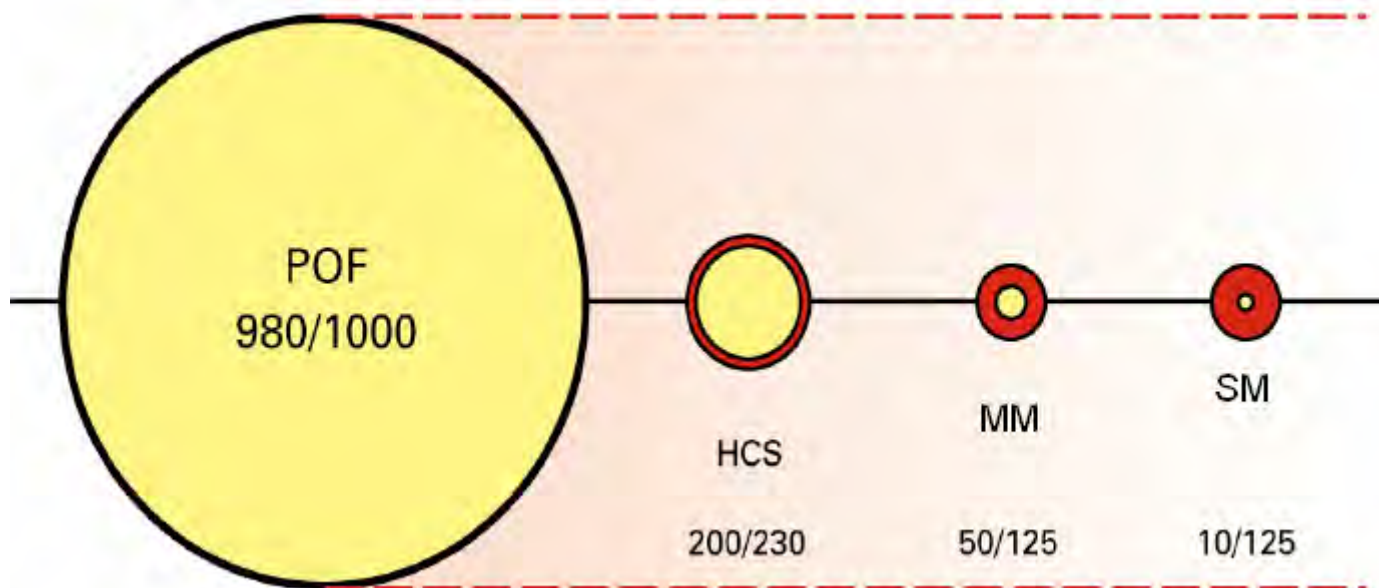

steklena vlakna

premer jedra
9 (8-10)
50 ali 62.5 mikronov,

125/250/700/900

v tesni ali ohlapni
zaščiti

SM in MM

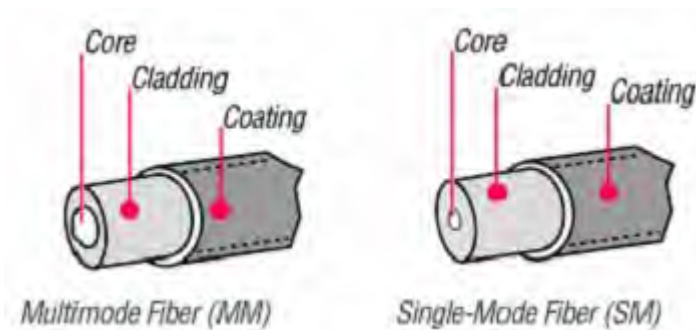
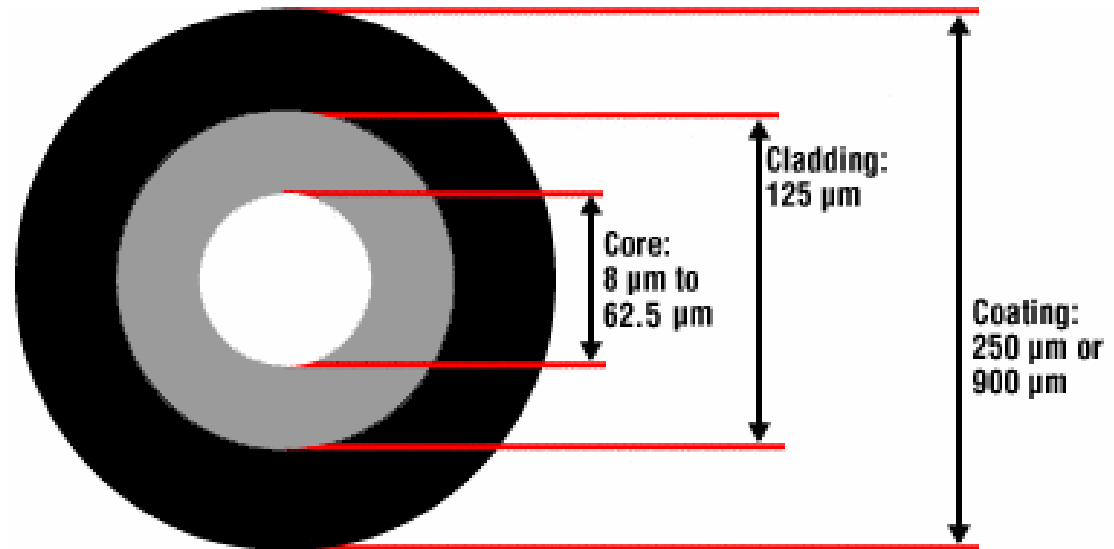

vlakno kot valovod

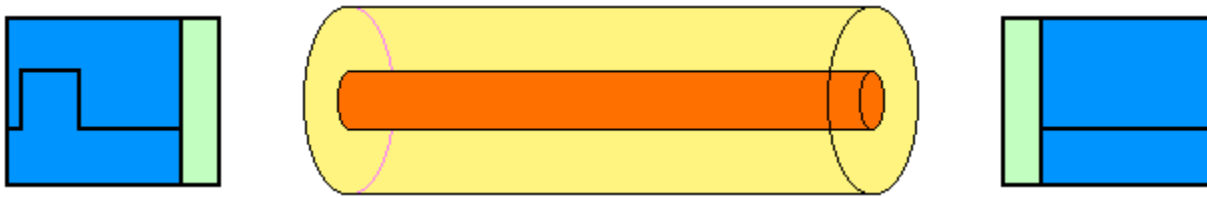

vlakna

steklo

1. SM 9/125
- 2a. MM 50/125 OM4 (40GbE in 100GbE)
- 2b. MM 50/125 OM3 (GbE in 10GbE)
- 2c. MM 50/125 OM2 (GbE)
3. MM 62.5/125 OM1
4. MM 62.5/125 (že inštalirana vlakna)

steklo / plastika

5. HCS 200/230 OH1

plastika

6. POF 200/490 OP2 (120/490)
7. POF 975/1000 OP1

POF, HCS in PCF vlakna

POF (plastična vlakna) 975/1000 do 40m (0.25 dB.m)

HCS (Hard Clad Silica) ali Polymer Clad Fiber 200/230, 200MHz.km@850nm za industrijsko avtomatizacijo

PCF (Photonic Crystal Fibres) nova tehnologija, 2002/2003 (steklene cevke premera 0.05mm med izdelavo še zmanjšajo za faktor 20)

PCF vlakna

Photonic Crystal Fiber

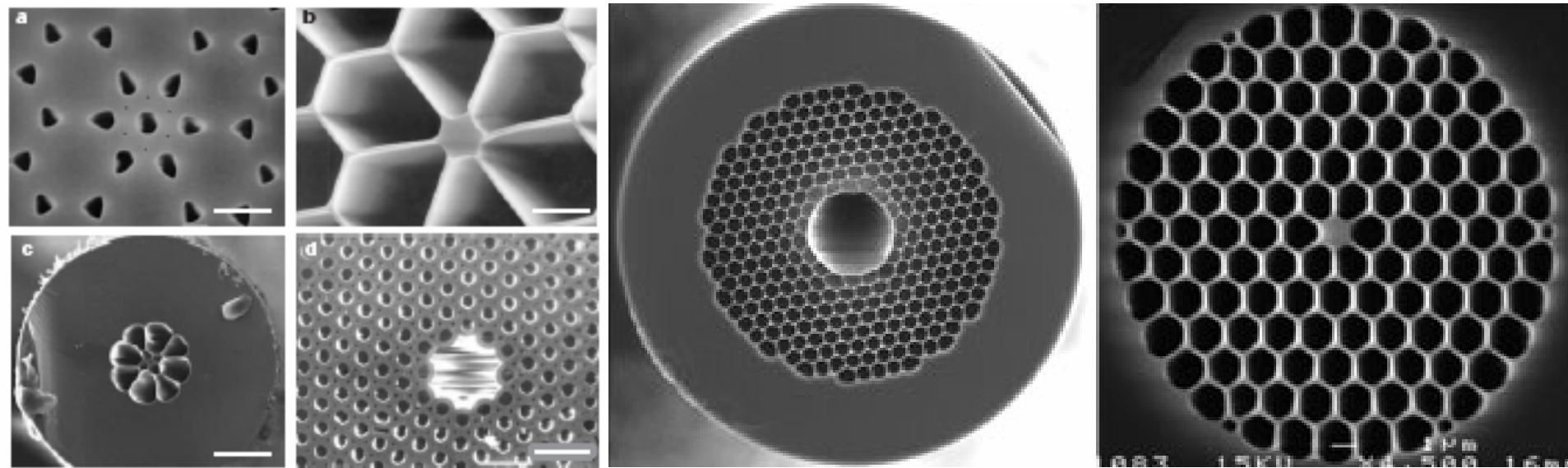

(premer zračne reže je nekaj mikrometrov)

Uporaba za spektroskopijo, metrologijo, biomedicino, telekomunikacije, industrijsko avtomatizacijo, raziskave, orožje, ..

vlakna

Prednosti

dolge prenosne poti, 100 in več km brez ojačevalnikov, nizko dušenje, neobčutljivost na elektromagnetne motnje, velika pasovna širina, teža, dimenzije, varnost, ..

Zgodovina

Leta 1950 iznajdba laserja in leta 1970 prva komercialna raba optičnih vlaken

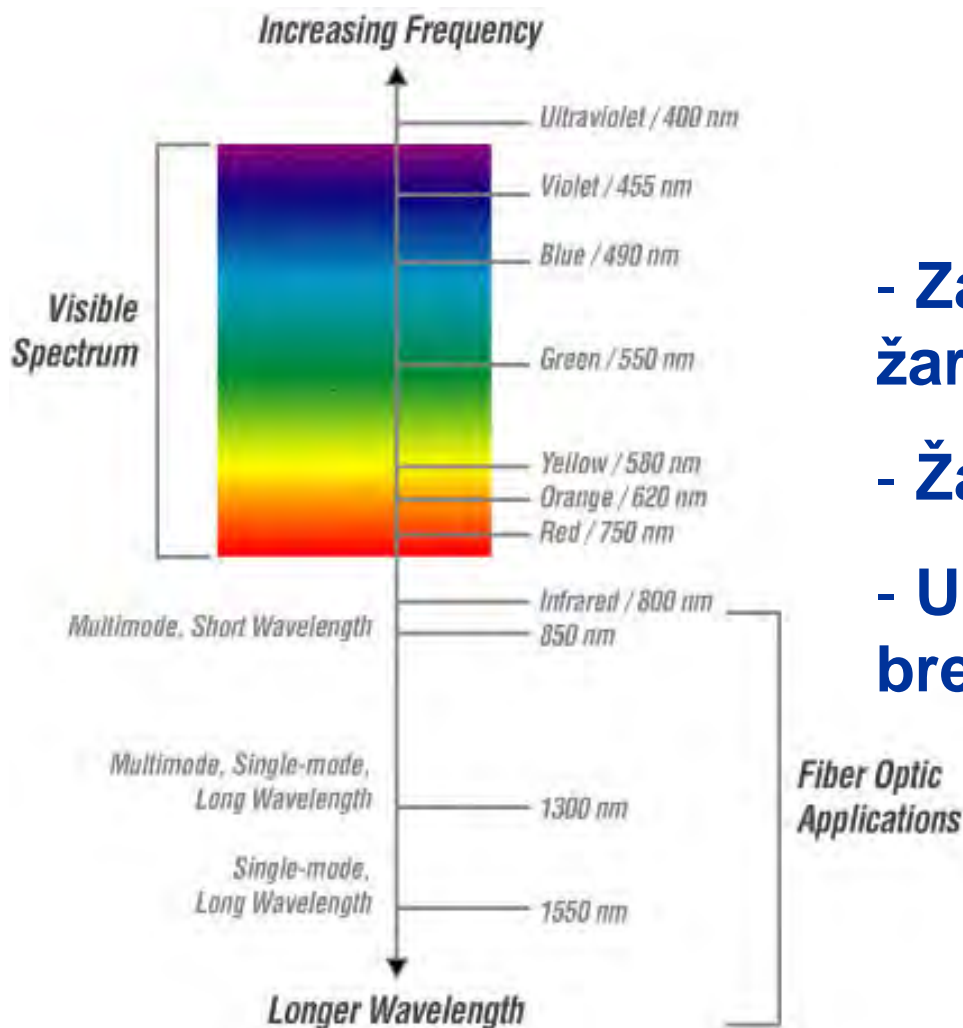

- Zaznavanje laserskega žarka
- Zaščita oči, kože, ..
- Ugotavljanje komunikacije brez prekinitve

Zaznavanje IR spektra

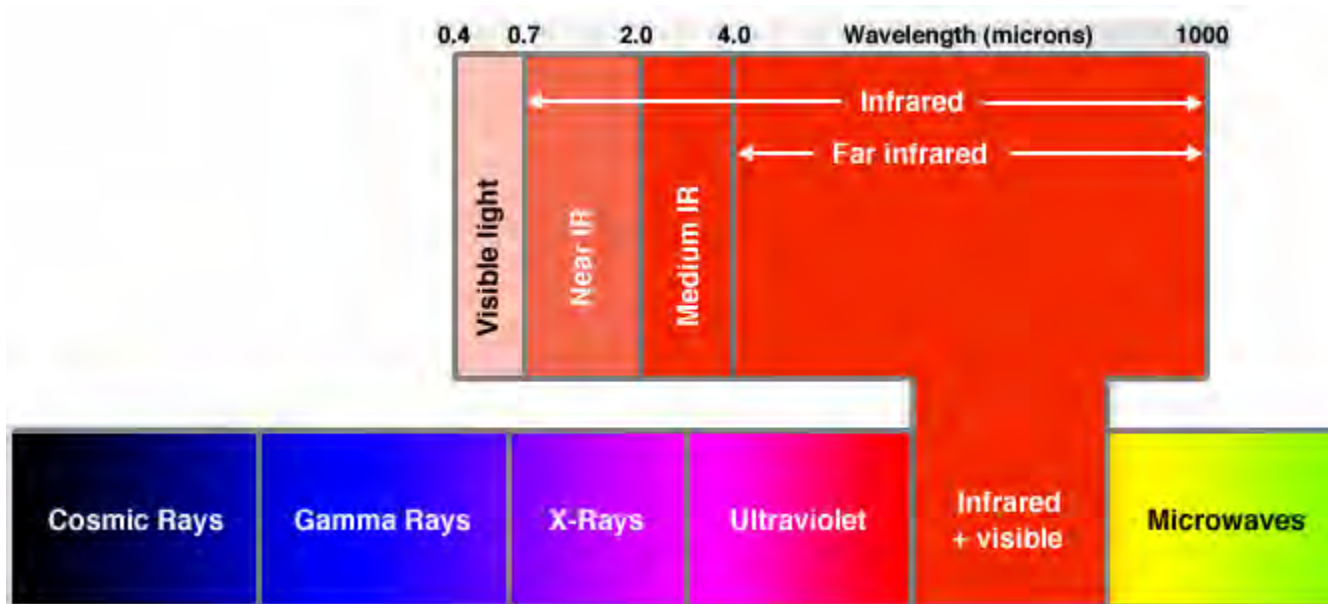

vlakno in kabel

Loose tube, ohlapna zaščita, 0.25 mm, varjenje, pig tail-li, zunanji, zahtevna raba

Tight buffer, tesna zaščita, **0.7** ali 0.9 mm, montaža konektorjev, notranji, manj zahtevna raba

Notranji, notranji/zunanji, zunanji, zemeljski, zračni, nekovinski, kovinski, samonosni, ..

Optični kabli

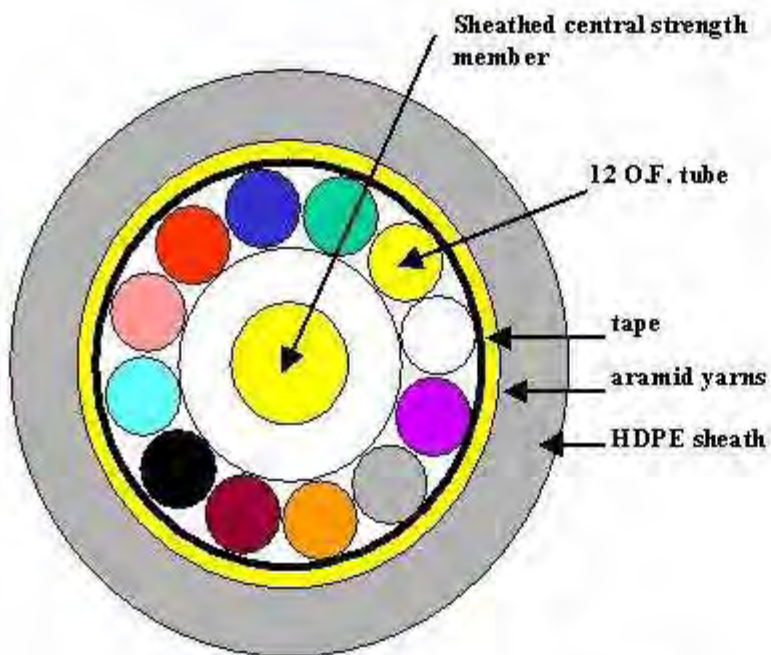

Diameter ~ 21,0 mm - Weight ~ 300 kg/km

“Drop” FTTH kabel

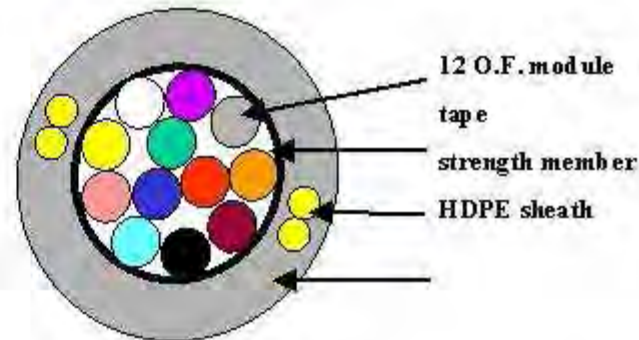

Diameter ~ 12,8 mm - Weight ~ 118 kg/km



Optični kabli



432 OF duct cable - Ø20.0 mm

**SMAN kabli,
proizvajalec Silec Cable**

Super-units
covered with thin,
easily removable,
coloured sheath

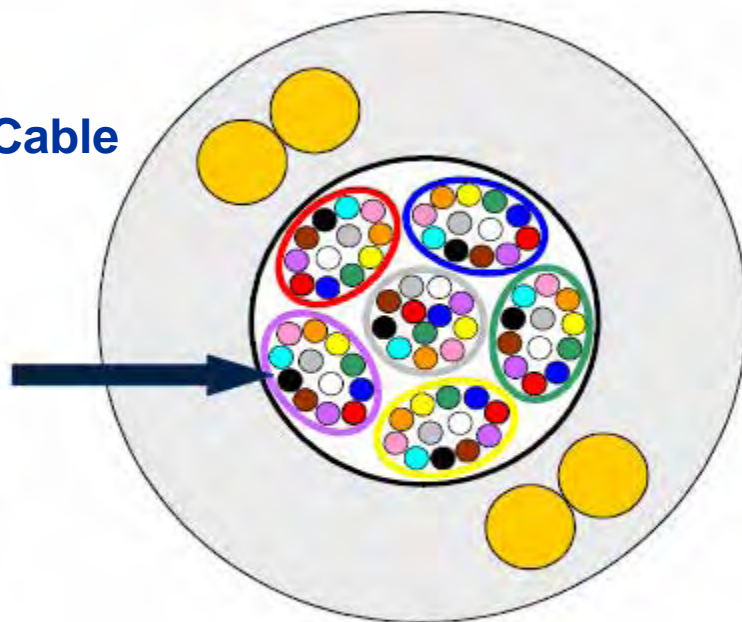

864 OF duct cable - Ø24.5 mm

Mreža cevčk

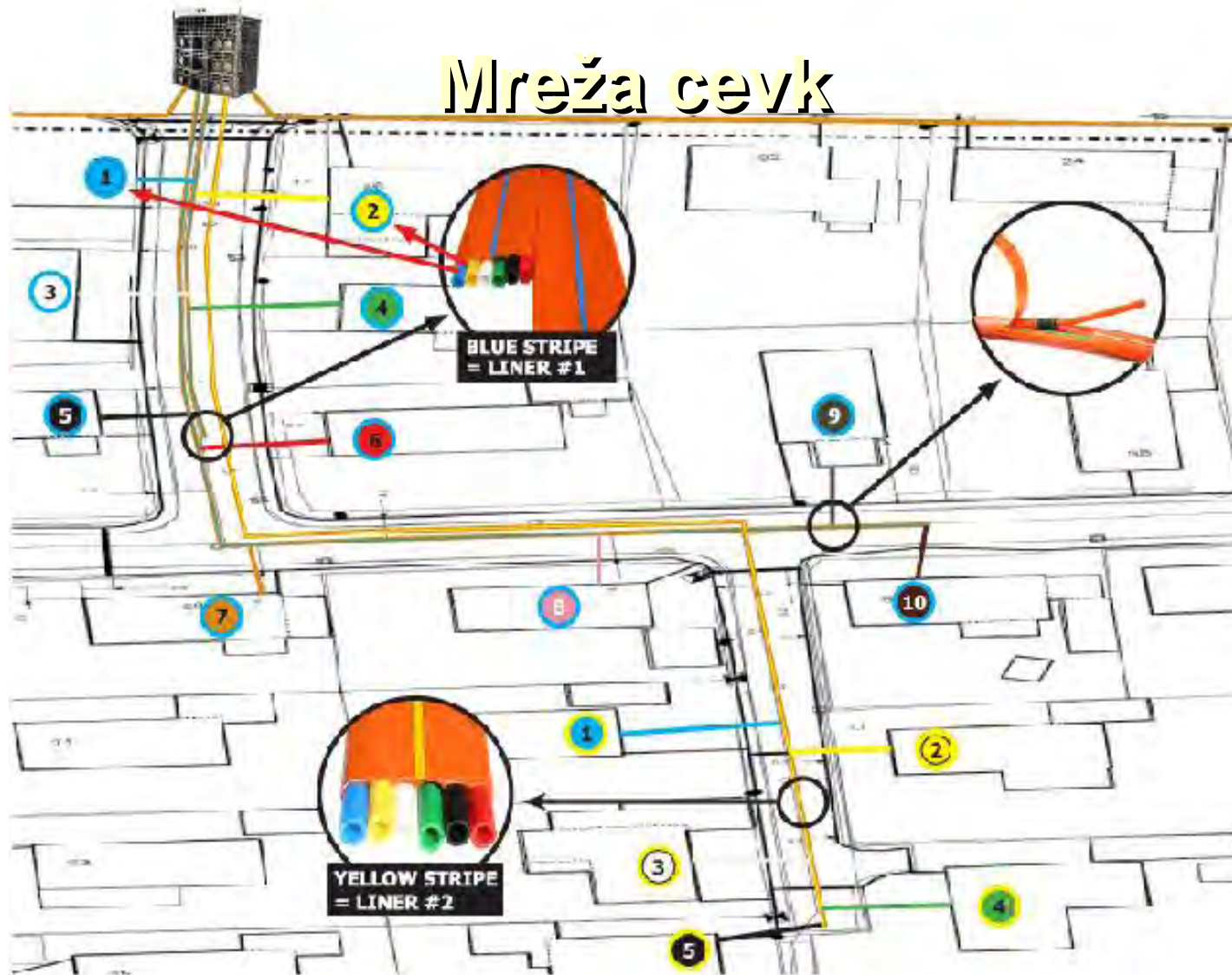

OPGW, ADSS, Figure 8

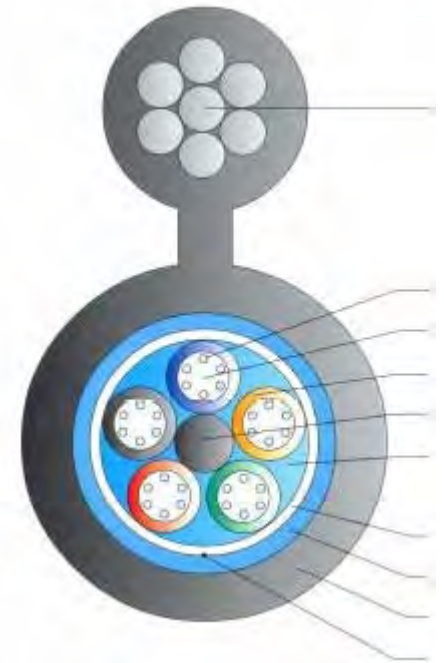
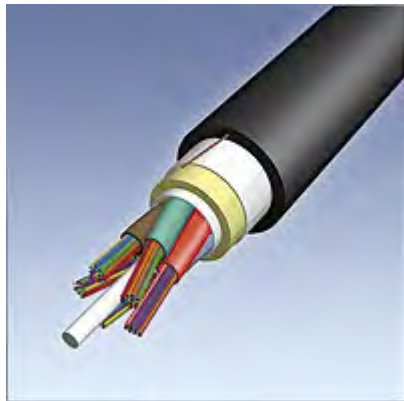
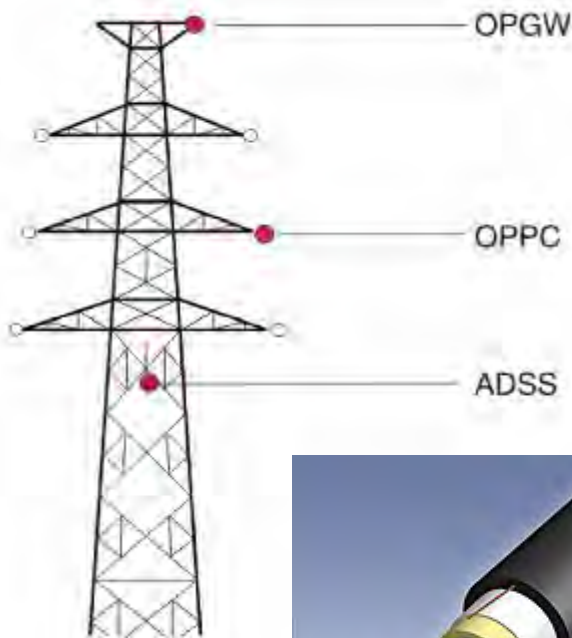

OPGW obešala



standardi - vlakna

ITU-T standard

G.651 Multimode optical fibers

G.652 Single Mode Dispersion Un-shifted

G.653 Single Mode Dispersion Shifted

G.654 Single Mode Cut-off shifted

G.655 Single Mode Non-zero Dispersion Shifted

G.656 Single Mode Low Dispersion slope Non-zero Dispersion Shifted

G.657 Single Mode Bending Insensitive

Description	IEC SMF Type	ITU Spec	TIA Spec
Standard Singlemode Fiber	B1.1	G.652	OS1
Cutoff Shifted Fiber	B1.2	G.654	
Low Water Peak Fiber	B1.3	G.652	OS2
Dispersion Shifted Fiber	B2	G.653	
Non-Zero Dispersion Shifted Fiber	B4	G.655	



OM4 in OS2

Cabled optical fibre Category	Maximum attenuation (dB/km)		Minimum modal bandwidth MHz×km
	850 nm	1 300 nm	850 nm
OM1	3,5	1,5	200
OM2	3,5	1,5	500
OM3	3,5	1,5	2 000
OM4	3,5	1,5	4 700

Cabled optical fibre Category	Maximum attenuation (dB/km)		
	1 300 nm	1 383 nm	1 550 nm
OS1 (EN)	1,0	1,0	1,0
OS1 (ISO/IEC)	1,0	-	1,0
OS2	0,4	0,4	0,4

OP1, OP2 (2007) in OH1

	Wavelength (nm)	Multimode			Wavelength (nm)	Singlemode	
		50/125 or 62.5/125	50/125			OS1	OS2
		OM1	OM2	OM3			
α (dBkm ⁻¹ max)	850	3,5			1310	1,0	0,4
	1300	1,5			1383		0,4
					1550	1,0	0,4
Modal bandwidth OFL (MHz.km min)	850	200	500	1500			
	1300	500	500	500			
Modal bandwidth LL (MHz.km min)	850	-	-	2000			
	1300	-	-	-			
Propagation delay (ns.m ⁻¹ max)	850	5			1310	5	5
	1300						
λ_c (nm max)					1260		
	Wavelength (nm)	Multimode					
		975/1000	200/490	200/230			
		OP1	OP2	OH1			
α (dBkm ⁻¹ max)	650	200	100				
	850		40	10			
	1300		40				
Modal bandwidth OFL (MHz.km min)	650	10	80				
	850		150	5			
	1300		150				
Propagation delay (ns.m ⁻¹ max)	650	5					
	850						
	1300						

IEC 60793-2-40:2006 as amended 2009

OP1 in OP2 (2010)

OF category	A4a1	A4a2	A4b	A4c	A4d	A4e	A4f	A4g	A4h
Core diameter (µm)	(Cladding diameter - 25) ± 10						200 ± 10	120 ± 10	62.5 ± 5
Cladding diameter (µm)	1000 ± 60	1000 ± 60	490 ± 10	500 ± 30	1000 ± 60	750 ± 45	490 ± 10	490 ± 10	245 ± 5
NA	0.5 ± 0.15	0.5 ± 0.03	0.5 ± 0.15		0.3 ± 0.05	0.25 ± 0.07	0.19 ± 0.015		
Attenuation (dB/100 m)									
@ 650 nm							-	≤ 10	≤ 10
@ 650 nm overfilled	≤ 40	≤ 18	≤ 40						
@ 650 nm equilibrium	≤ 30	≤ 18	≤ 30						
@ 650 nm 0.3 NA							≤ 18		
@ 850 nm							≤ 4	≤ 3.3	≤ 3.3
@ 1300 nm							≤ 4	≤ 3.3	≤ 3.3
Bandwidth (MHz.100m)									
@ 650 nm	≥ 10						≥ 800	≥ 800	
@ 650 nm 0.3 NA	-	-	-	-	≥ 100	≥ 200			
@ 850 nm							≥ 1500	≥ 1880	≥ 1880
@ 1300 nm							≥ 1500	≥ 1880	≥ 1880

Generic cabling standards selection - ISO/IEC 24702 A1:2009) and EN 50173-3 A.1 (expected in 2010).)

Cabled OF Category	OP1	OP2
Attenuation (dB/100 m)		
@ 650 nm	≤ 18	≤ 10
@ 850 nm	-	≤ 3.3
@ 1300 nm	-	≤ 3.3
Bandwidth (MHz.100m)		
@ 650 nm	≥ 10	≥ 800
@ 850 nm		≥ 1880
@ 1300 nm		≥ 1880

standardi – kabel

(ZJPTT) TO SM 03 (m x n) II/III 0,38/3,5x0,25/19 CMAN/SMAN

TO	optični TK kabel
SM	eno rodovno optično vlakno
03	Ne armirani kabel s PE plaščem
m	število cevk v kablju
n	število optičnih vlaken v posamezni cevki
II	drugo valovno področje (1300 nm)
III	tretje valovno področje (1550 nm)
0,38	slabljenje eno rodovnega vlakna pri 1330 nm (dB)
0,25	slabljenje eno rodovnega vlakna pri 1550 nm (dB)
3,5	kromatska disperzija pri 1300 nm (ps/nm km)
19	kromatska disperzija pri 1550 nm (ps/nm km)
C (S)	optična vlakna v cevkah (mehke cevke)
M	polnjeni kabel
A	kabel z aramidnimi vlakni
N	kabel brez kovinskih elementov.



VDE oznake



1./2. Basic type

- A Outdoor cable
- AT Outdoor cable, separable
- I Indoor cable
- U Universal cable for in-and outdoor

3. Fibers

- D multi fibre loose buffer, filled
- V Tight buffer tube
- H Hollow, unfilled
- W Hollow, filled
- B multi fibre loose buffer, unfilled

4. Additional assembly element

- F Petrol jelly filling
- Q Water blocking tape
- S Metallic element in the cable core

5.

- 2Y
- (L)2Y
- (D)2Y
- (ZN)2Y

(L)(ZN)2Y

(D)(ZN)2Y

B

BY

B2Y

Sheath

- PE-sheath
- Laminated sheath
- PE-sheath with plastic barrier
- PE-sheath with non metallic strength member
- Laminated sheath with non metallic strength member
- PE-sheath with plastic barrier and non metallic strength member
- Armouring
- Armouring with PVC-protection sheath
- Armouring with PE- protection sheath



VDE oznake

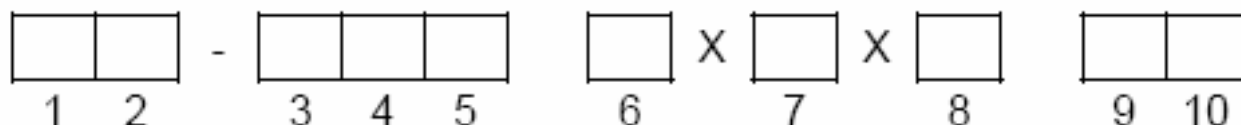

6. Number of fibers

10. Attenuation coefficient in dB/km

7. Fiber typ

11. Optical windows

- G Gradient fiber glass/glass
- E Single mode fiber glass/glass
- S Step-index fiber glass/glass
- K Step-index fiber glass/plastic

- A 650 nm
- B 850 nm
- F 1300 nm
- H 1550 nm

8. Diameter of core

12. Bandwidth in MHz and dispersion in ps/nm/km

9. Diameter of cladding

VDE oznake

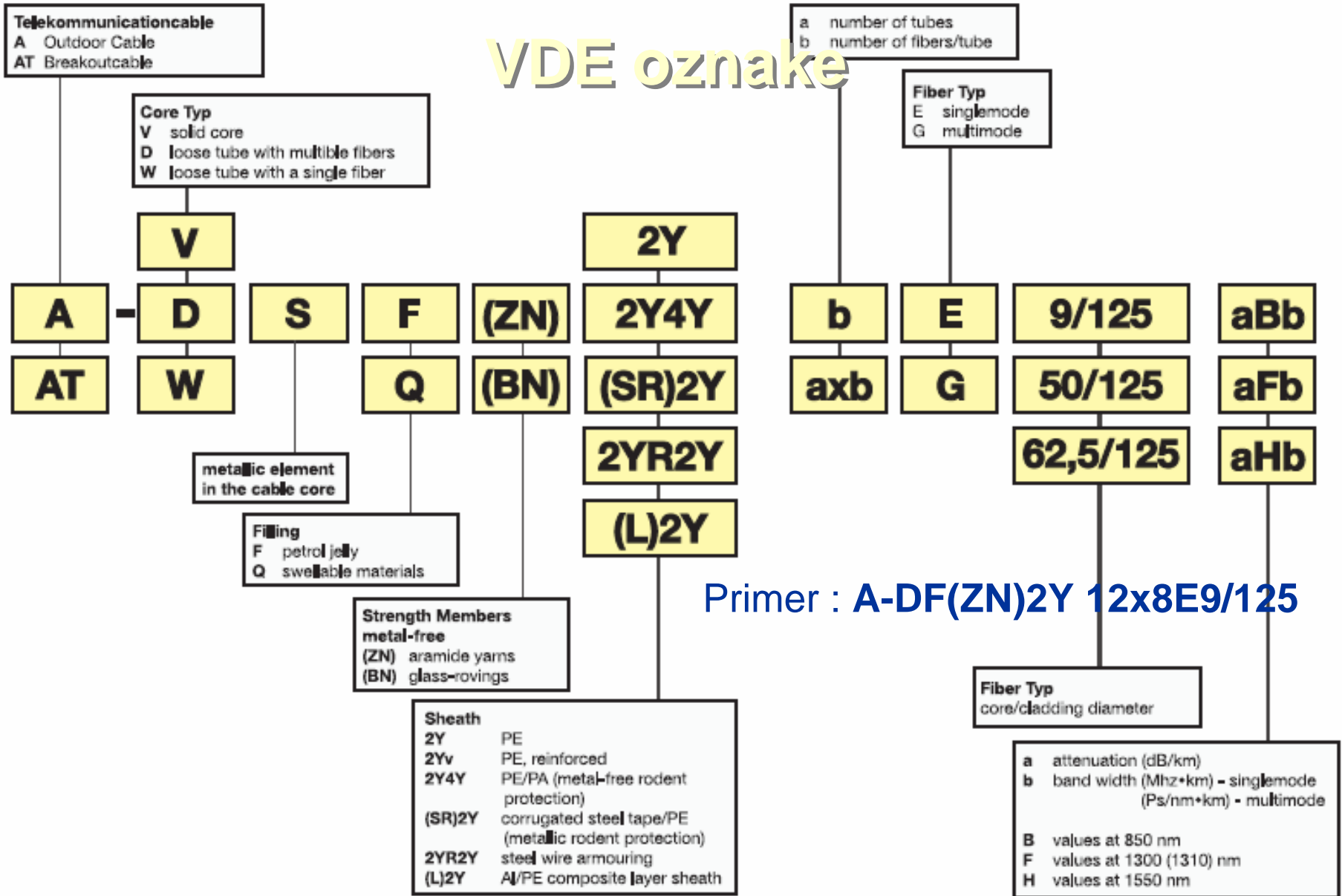

Ozemljitev in oklopi

- 1
Glavna ozemljitvena mreža
- 2
Ozemljitev omare in rack-a
- 3
Ozemljitev opreme v rack-u

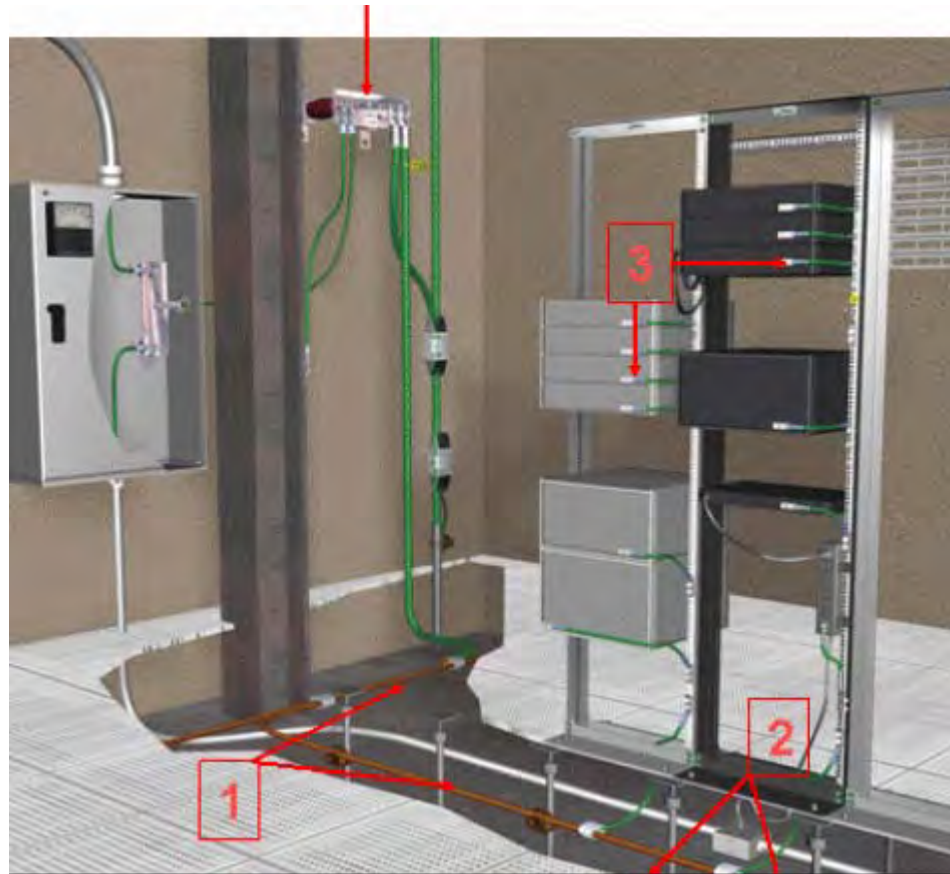

Ozemljitev in oklopi

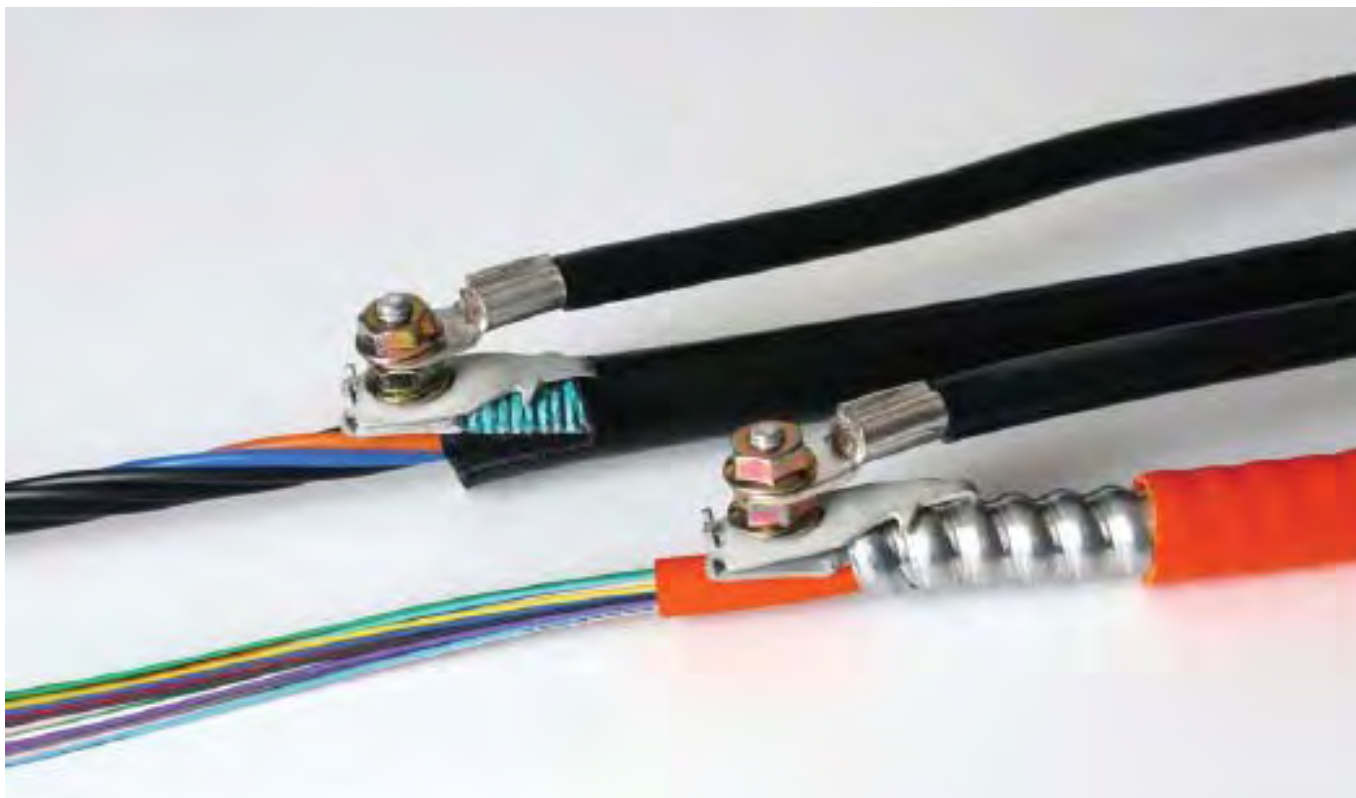

spojniki in konektorji za optična vlakna

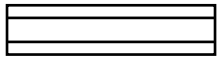

Spojniki

ST - ST
ST/ST - ST/ST
SC - SC
SC/SC - SC/SC(duplex)
SC - ST
SC/SC - ST/ST

Konektorji

ST
SC, SCD (duplex)
FCPC, FCUPC, FCAPC
SFF

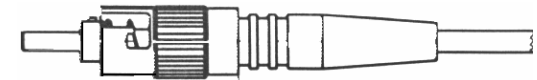

ST

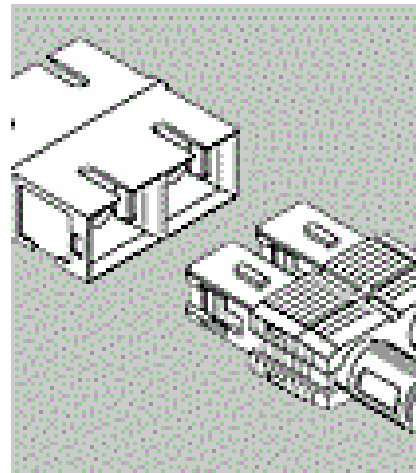

SC, SC duplex

spojniki in konektorji za optična vlakna

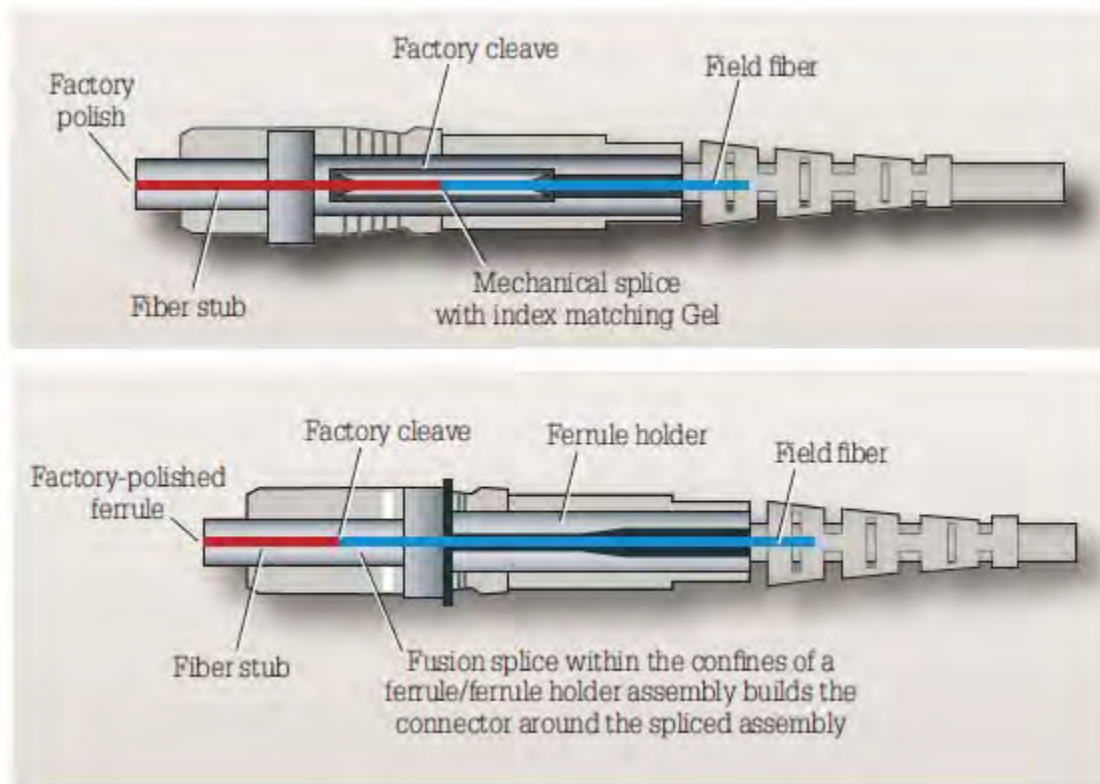

poliranje

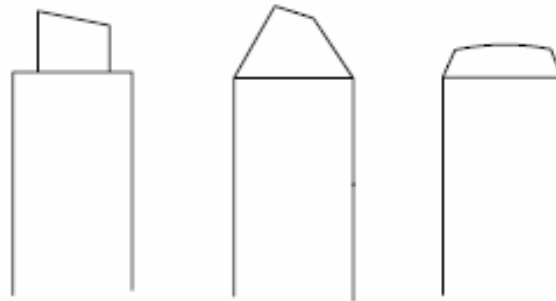

Stopničasto	Konično	Ovalno
APC	APC	UPC, PC

	FC SM Simplex Pigtail	FC SM Adapter
Typical Insertion Loss	0.15 dB	
Maximum Insertion Loss	0.3 dB	
Return Loss (PC)	>-45 dB	
Return Loss (UPC)	>-50 dB	
Return Loss (APC)	>-60 dB	

SFF (Small Form Faktor) konektroji

FJ
(OptoJack)



LC



MT-RJ



VF-45





(SFF) konektorji



MU



E2000

MTP/MPO
4, 8, 12, 24, 72

LC Multicomponent connectors



LX5



ferule premera 1.25(SFF) ali 2.50mm

MTP (Mechanical Transfer Pull Off), MPO (Multi-fiber Push-On)

(SFF) konektorji

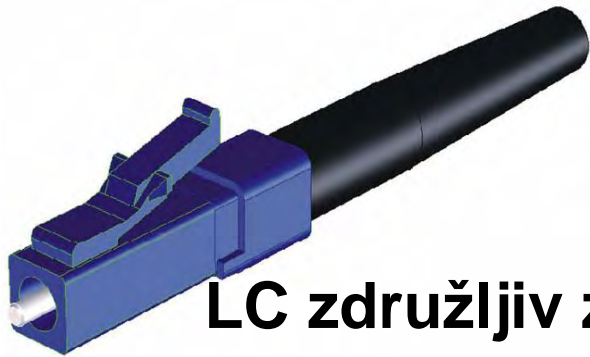

LC združljiv z F3000

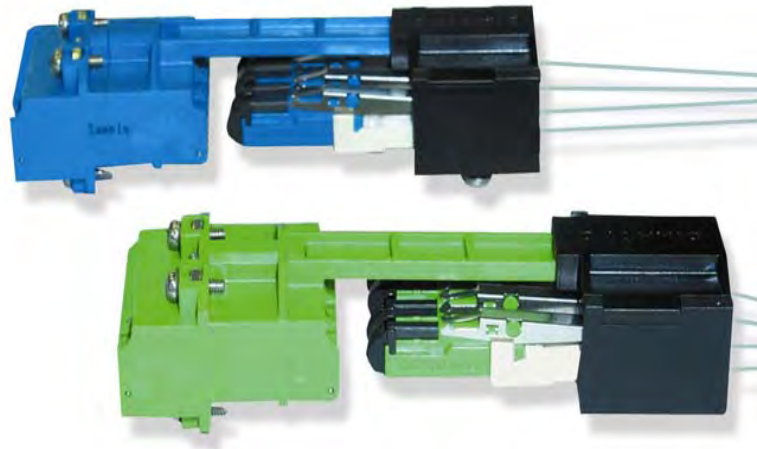
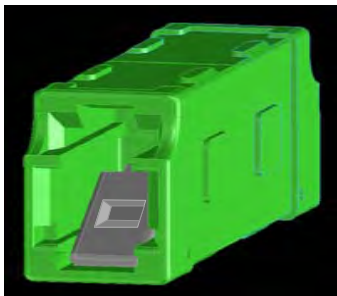

F3000 Diamond
0.1 dB (IL)
do 85 dB (RL)

(POF) konektorji



(FSMA kovinska ferula premera 3.20mm)



Delilniki in spojke



Posebni varilniki in rezalniki



ARCMaster FSM-100P



Vytran FFS-2000



York FK12

Kaj je dB

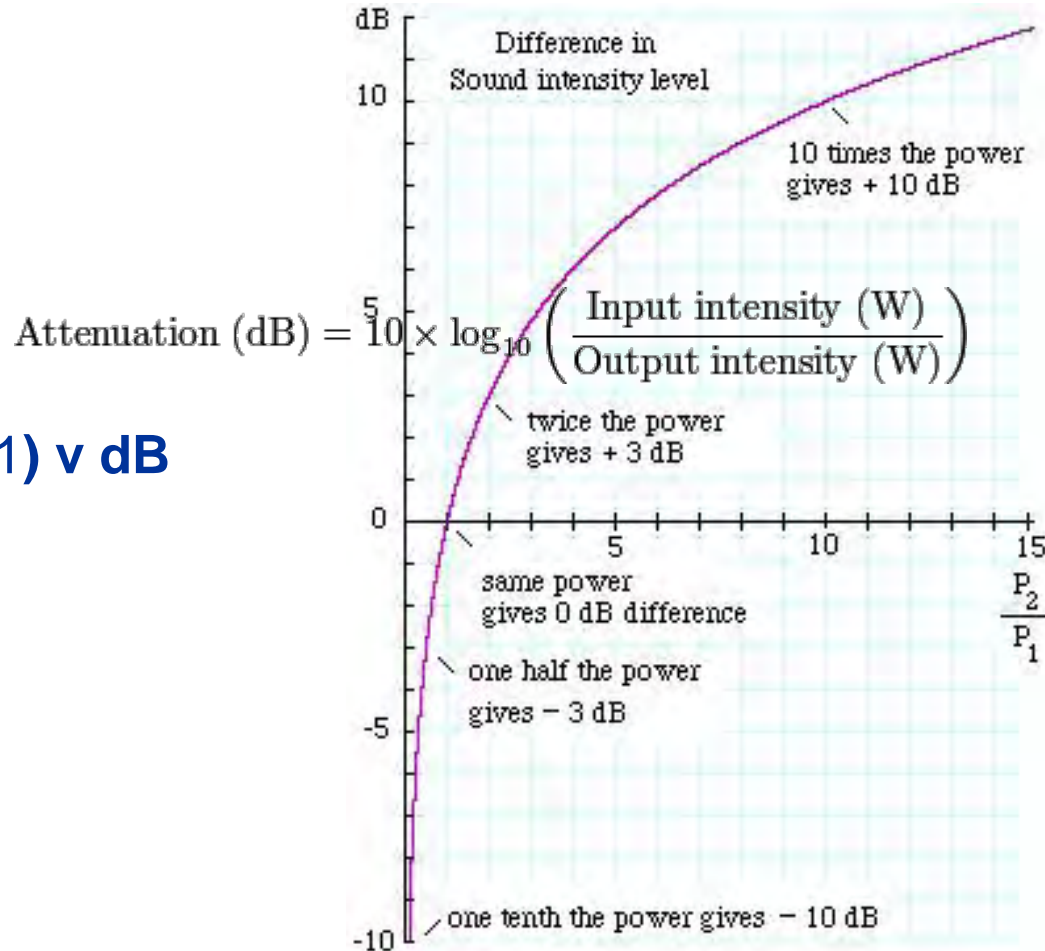

10log(P2 / P1) v dB

Kaj je dBm

Once you get used to it, you will never want to return to watts. Units of dBm are decibels relative to 1 mW of power, hence, 0 dBm 1 mW. 1/100 mW is -20 dBm and 100 mW is +20 dBm. Powers less than 1 mW are always negative dBm values, and powers greater than 1 mW are always positive.

$$P(\text{mW}) = 10^{[P(\text{dBm})/10]}$$

$$P(\text{dBm}) = 10 \cdot \log[P(\text{mW})]$$

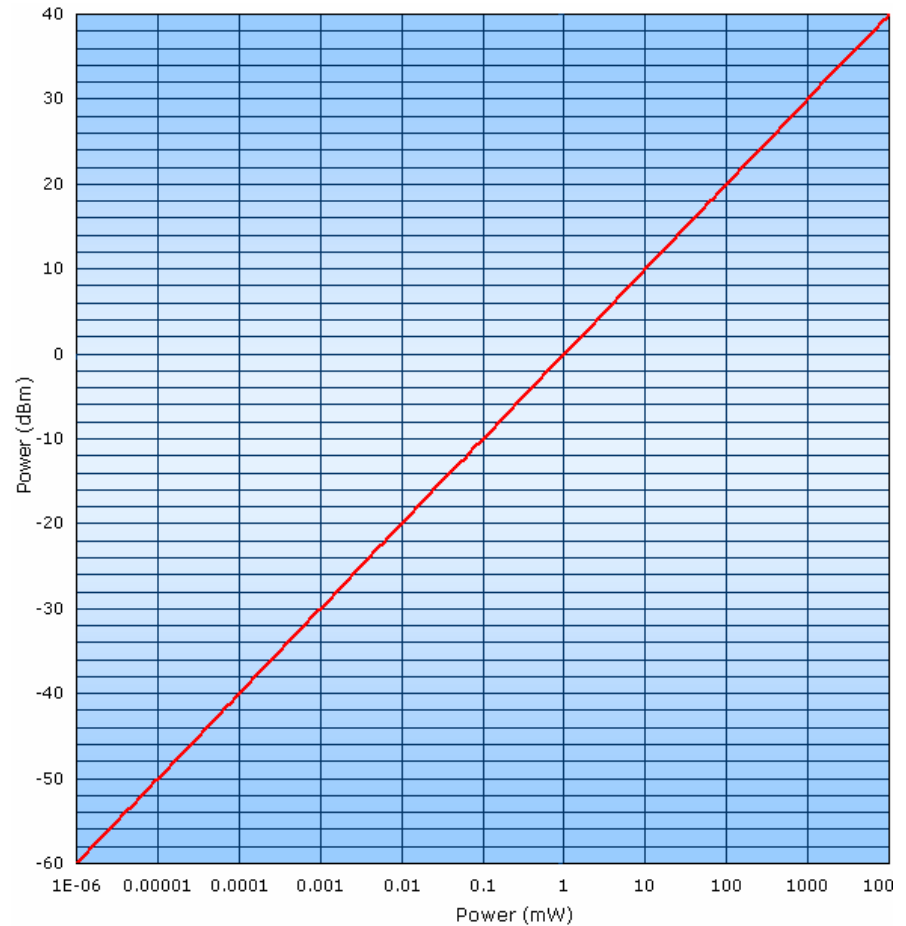

Kaj je bit in Bajt

	Bytes	Bits
1 bit =	.125 byte. =	1 bit.
1 byte =	1 byte. =	8 bits
1 kilobyte =	1024 bytes =	8192 bits
1 megabyte =	1048576 bytes =	8388608 bits
1 gigabyte =	1073741824 bytes =	8589934592 bits
1 terabyte =	1099511627776 bytes =	8796093022208 bits
1 petabyte =	1125899906842624 bytes =	9007199254740992 bits
1 exabyte =	1152921504606846976 bytes =	9223372036854775808 bits
1 zettabyte =	1180591620717411303424 bytes =	9444732965739290427392 bits
1 yottabyte =	1208925819614629174706176 bytes =	9671406556917033397649408 bits
1 xonabyte =	1237940039285380274899124224 bytes =	9903520314283042199192993792 bits
1 wekabyte =	1267650600228229401496703205376 bytes =	10141204801825835211973625643008 bits
1 vundabyte =	1298074214633706907132624082305024 bytes =	10384593717069655257060992658440192 bits

bit ali binary digit je najmanjša info enota (1, 0)

Byte je znak ali skupina dolga 8 bitov

- * 1 bit: a binary decision
- * 1 byte: a character
- * 5 Megabytes: The complete works of Shakespeare
- * 2 Gigabytes: 20 meters of shelved books
- * 10 Terabytes: The printed collection of the US Library of Congress
- * 200 Petabytes: All printed material
- * 5 Exabytes: All words ever spoken by human beings

Ethernet razdalje

vlakno	pas. širina (MHz/km)	val. dolžina (nm)	mrežni standard	dolžina (m)
62.5/125	200	850	10/100Base-FX	2000
62.5/125	200	850	1000Base-SX	275
62.5/125	500	1310	1000Base-LX	550
50/125	500	850	1000Base-SX	550
9/125	/	1310	1000Base-LX	2000
50/125	400	850	IEEE 802.3ae	65
62.5/125	160*	1310(WWDM)	IEEE 802.3ae	300
9/125	/	1310(WWDM)	IEEE 802.3ae	10000
9/125	/	1310	IEEE 802.3ae	10000
9/125	/	1550	IEEE 802.3ae	40000

* že inštaliran kabel

WWDM(Wide Wave Division Multiplexing)

10 GbE (IEEE 802.3ae) po MM vlaknu

10GBASE-SR

vlakno	MHz/km pri 850/1310nm	kategorija/tip	povezava na izvor	dolžina
62.5/125	160/500	FDDI	preko MC p. kabla	26
62.5/125	200/500	OM1	preko MC p. kabla	33
50/125	500/500	OM2	preko MC p. kabla	82
50/125	1500/500	OM3	neposredno	300

10GBASE-LRM

vlakno	MHz/km pri 850/1310nm	kategorija/tip	povezava na izvor	dolžina
62.5/125	160/500	FDDI	preko MC p. kabla	220
62.5/125	200/500	OM1	preko MC p. kabla	220
50/125	500/500	OM2	preko MC p. kabla	220
50/125	400/400	A1a.1	preko MC p. kabla	100
50/125	1500/500	OM3	neposredno	300

VCSEL

VCSEL (Vertical Cavity Surface Emitting Laser) ali laser z navpično resonančno votlino je komercialno na voljo za valovno dolžino 850nm (in 1300nm)

VCSEL se uporablja tudi pri 10GbE

cena je primerljiva z LED

Figure 1.

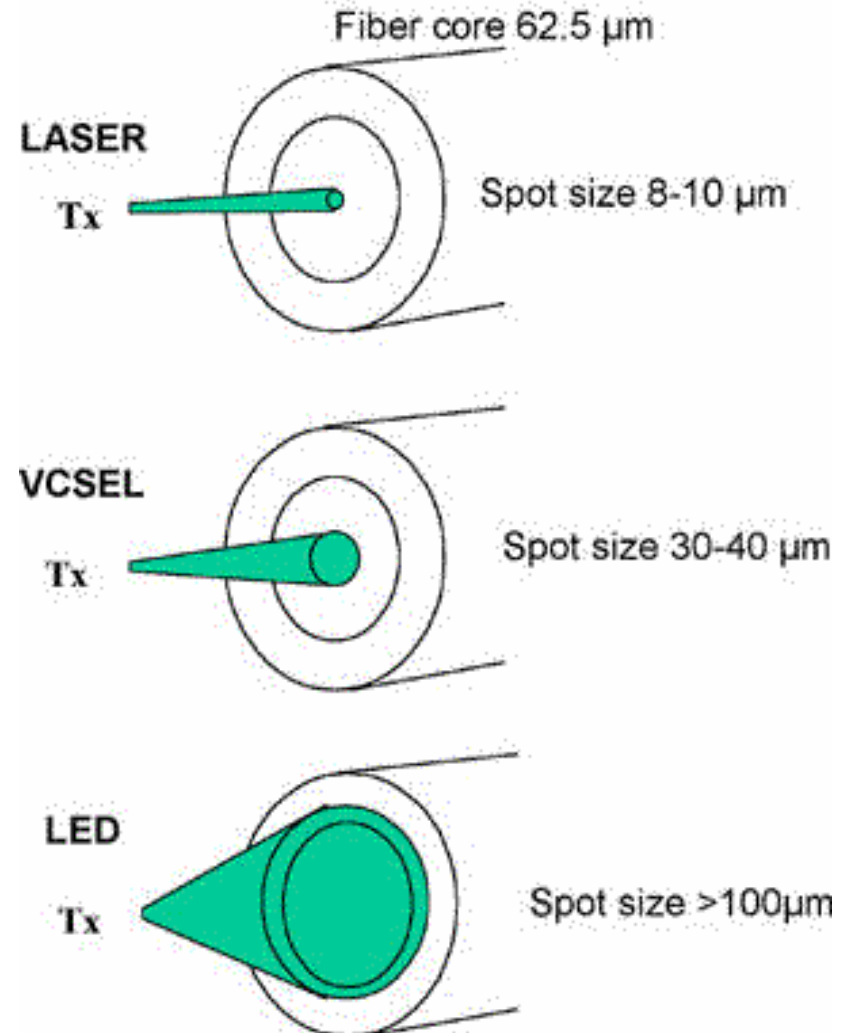



Prilagoditveni (Mode conditioning) kabel

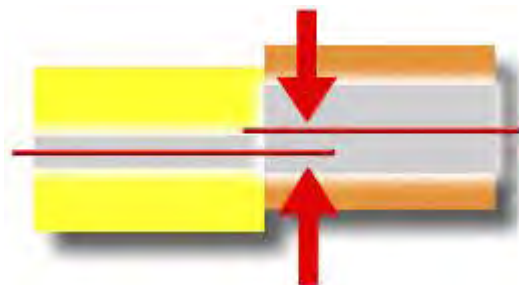

EFM(IEEE 802.3ah)

EFM po optiki (eno ali dve vlakni OS1), točka točka (P2P) za neposreden dostop

EFM po optiki (eno ali dve vlakni OS1), točka več točk (P2MP) preko pasivne optične mreže (EPON za FTTx)

EFM po bakru (EFMC), po večih paricah (SHDSL)

**EFM po bakru, po eni parici,
kot dolgi doseg za komercialno rabo (SHDSL) in
kot kratki doseg za domačo rabo (VDSL)**

ITU-T G.984 GPON - Gigabit PON

Je drugapomembna FTTH in PON tehnologija.

Podpira Ethernet, ATM in TDM (Time-division multiplexing) po PON topologiji točka točka (P2P) ali po načinu točka več točk (P2MP).

Uporablja hitrost 1.25 Gigabitov na sekundo od uporabnika (upstream) in 2.5 Gb/s proti uporabniku (downstream). Podpira tudi VoIP servis.



EFM po optiki točka - točka (100BASE- LX & 100BASE- BX)

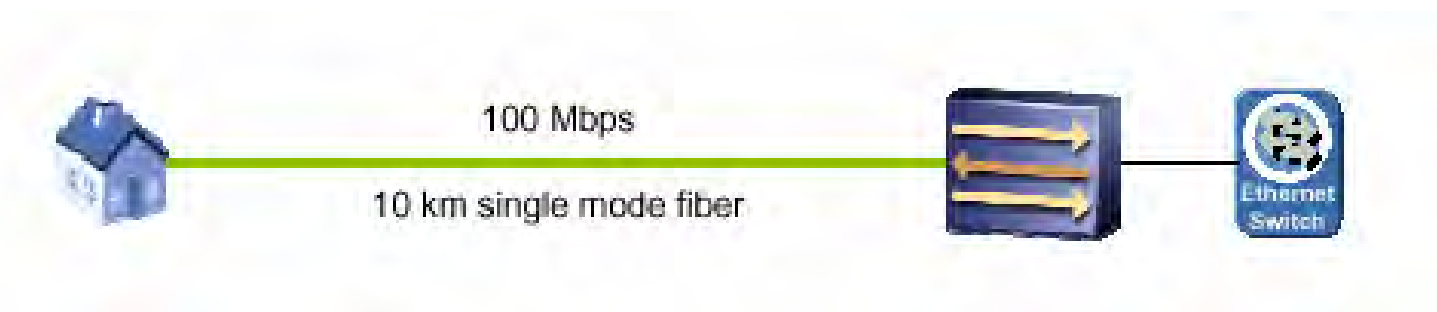

EFM po optiki točka - točka (1000BASE- LX & 1000BASE- BX)

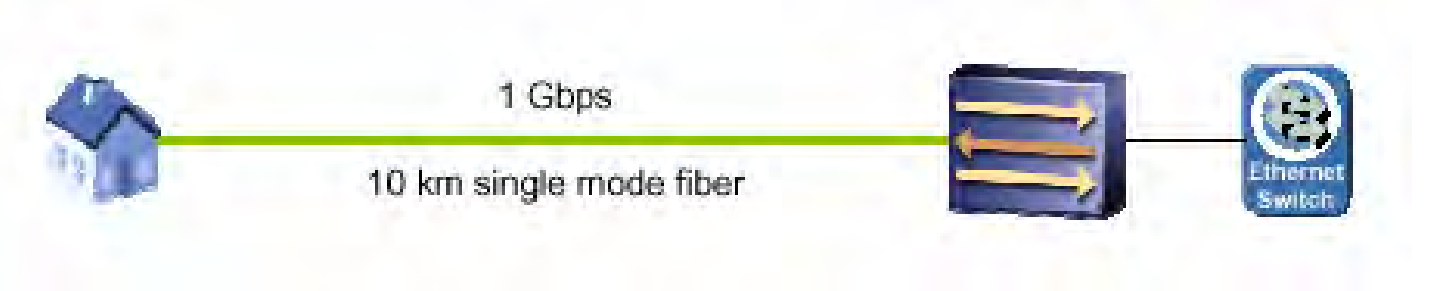

EFM po optiki točka - več točk (1000BASE-PX)



Pomen FTTH v EU, sofinanciranje širokopasovnega dostopa (GOŠO)

PON delilci (spliterji)

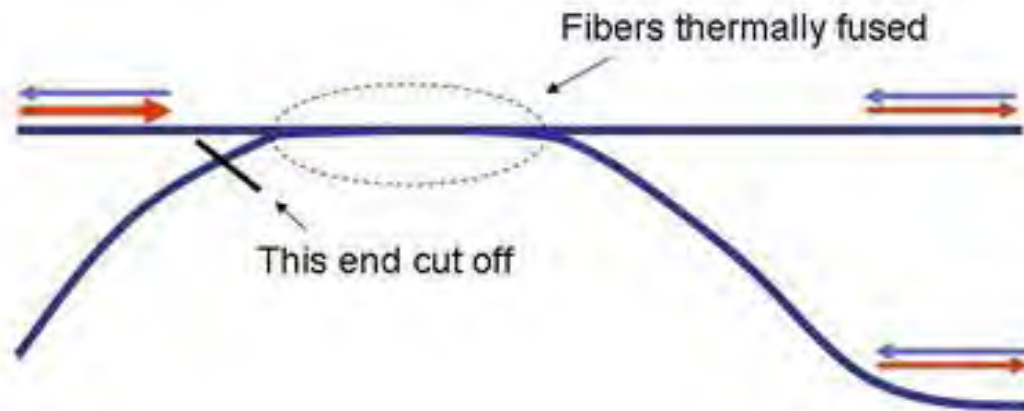

princip FBT (Fused Biconical Taper) delilca

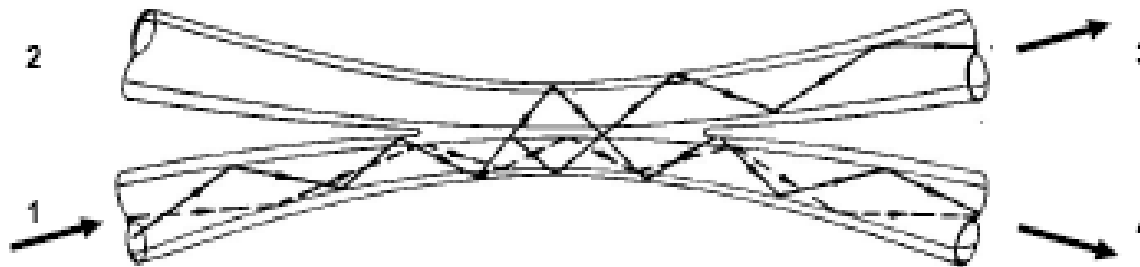

PON delilci (spliterji)

princip PLC (Planar Lightwave Circuit) delilca

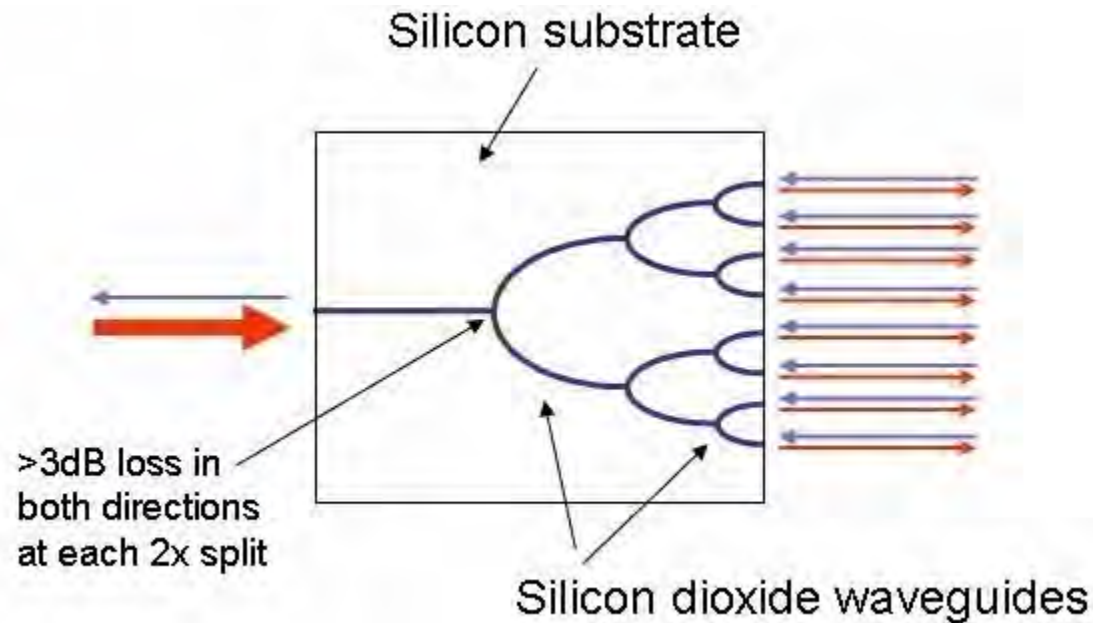

PON delilci (spliterji)

primer PLC delilca



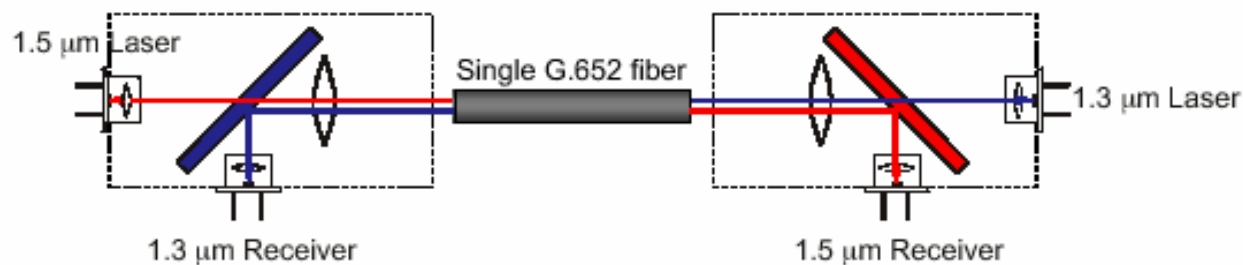

1 vlakno (OS1), 2 vlakna (OM1, OM2, OM3, OS1)



EFM(IEEE 802.3ah)

	100 Mbps	1000 Mbps
	SMF	SMF
Dual Fiber	100BASE-LX10 10 km	1000BASE-LX, 5 km 1000BASE-LX10, 10 km, extended temperature
Single Fiber	100BASE-BX10-D, 10 km 100BASEBX10-U, 10 km	1000BASE-10BX-D, 10 km 1000BASE-BX-U, 10 km

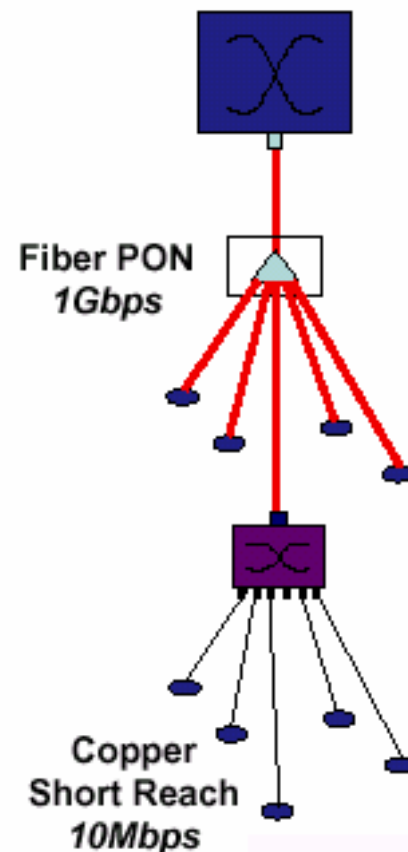
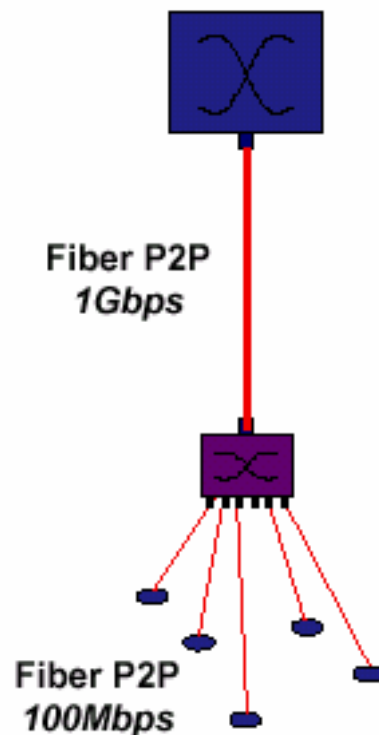
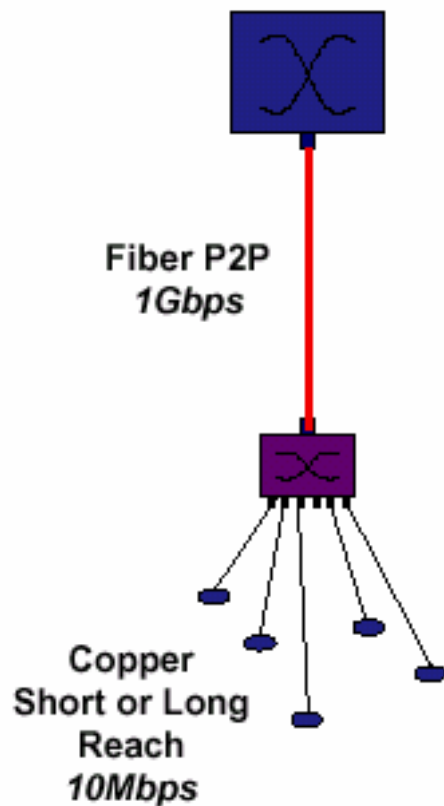

Optični kabelski sistemi

Passive Optical Network

© 2005 IPTV Information

PON

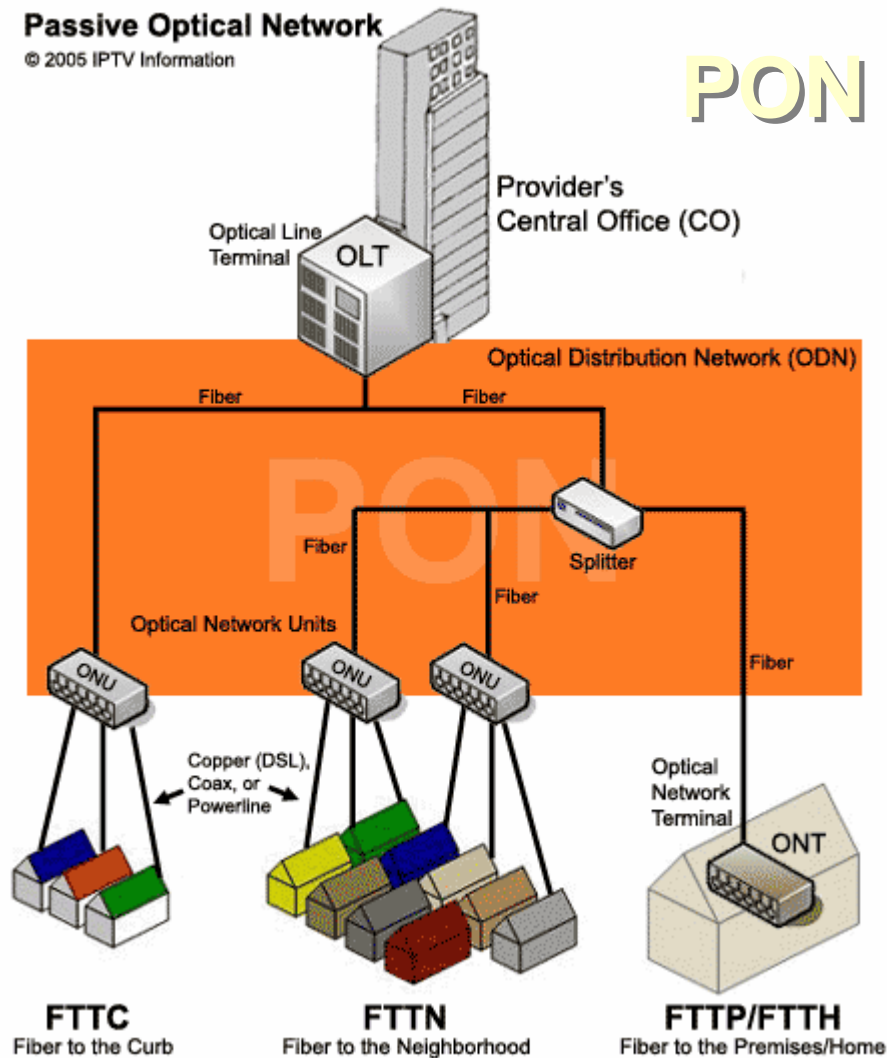

FTTx

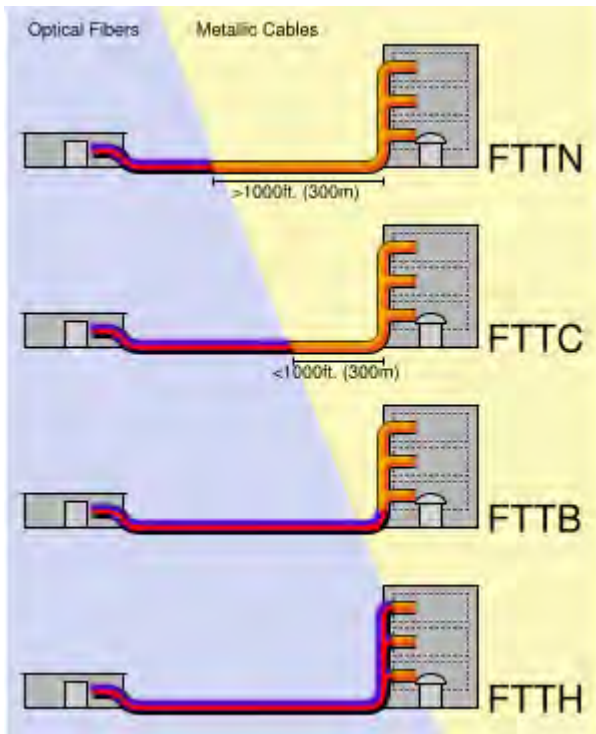

FTTN Node, Neighborhood ali Cabinet (FTTCab)

FTTC Curb ali Kerb (FTTK)

FTTB Building

FTTH Home ali Premises (FTTP)

FTTZ Zone

FTTx

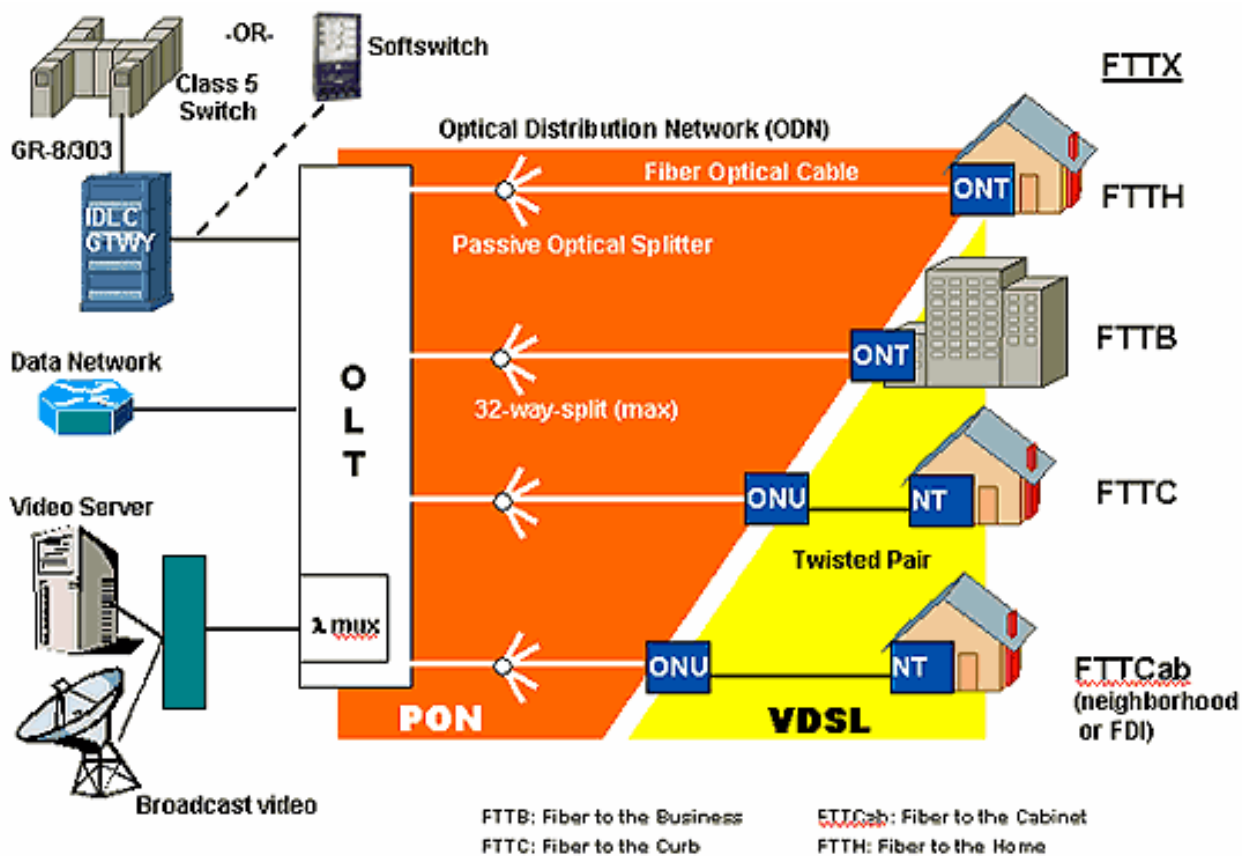

Centraliziran optični kabelski sistem

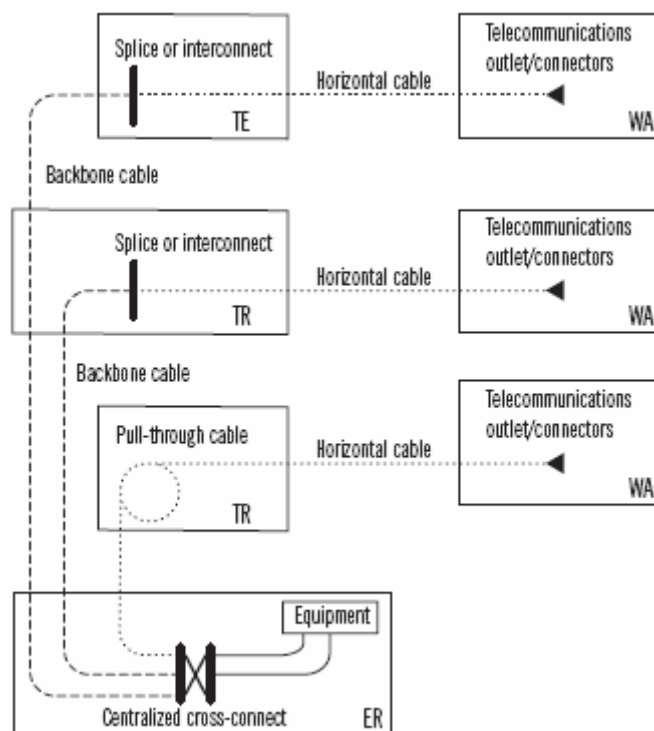



FTTx

	BPON	EPON	GPON
Standard	ITU-T G983	IEEE803.2ah	ITU-TG.984
pasovna širina	sprejem do 622 Mb/s	obojestransko do 1.25Gb/s	sprejem do 2.5Gb/s
	oddaja 155 Mb/s		oddaja 2.5Gb/s
sprejem λ (nm)	1490 in 1550	1550	1490 in 1550
oddaja λ (nm)	1310	1310	1310
prenos	ATM	Ethernet	ATM, Ethernet, TDM

BPON Broadband PON (včasih APON ATM PON)
EPON ali GE-PON - Gigabit Ethernet PON (EFM)
GPON - Gigabit PON (ITU-T G.984)

optična zveza

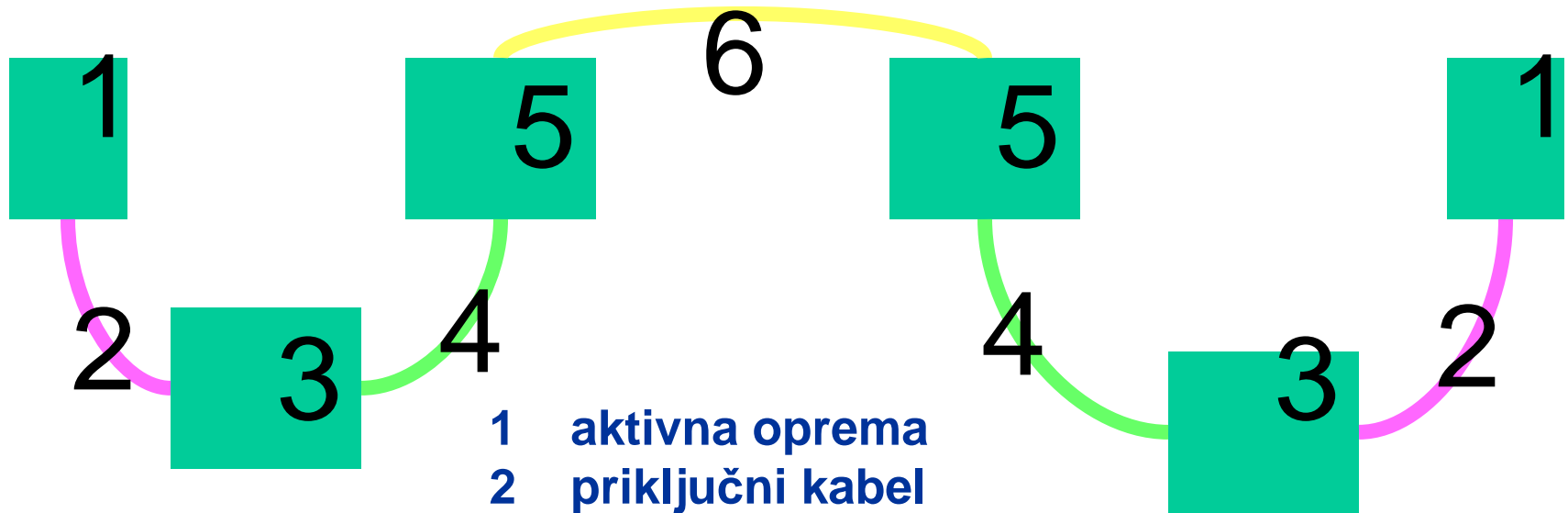

- 1 aktivna oprema
- 2 priključni kabel
- 3 FO pretvornik
- 4 FO priključni kabel
- 5 delilnik
- 6 Inštalacijski kabel



Pretvorniki in vmesniki



Single Fiber, Dual Fiber, SM, MM, PoE, ..

pretvorniki

brez ali z upravljanjem
zunanje ali notranje napajanje, 12/24/48/110VDC, 230VAC, PoE, USB
10Base-T na 2/FL, 10/100/1000Base-TX na FX



MM - SM



SFP





PoE pretvorniki

PoE* PD Powered Device, PoE* PSE Power Sourcing Equipment

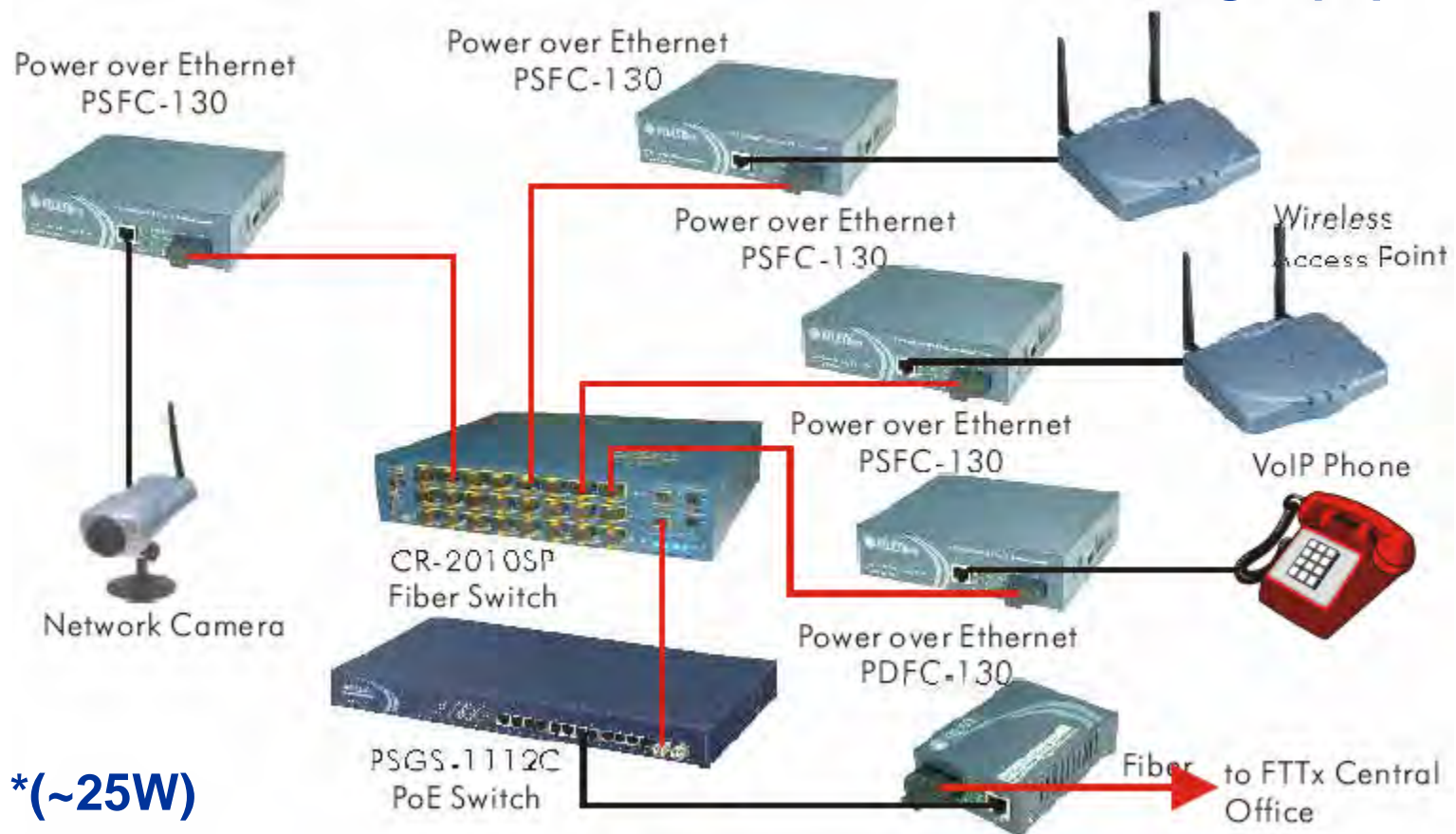



1 Gbitni vmesniki



LC SFP



RJ45

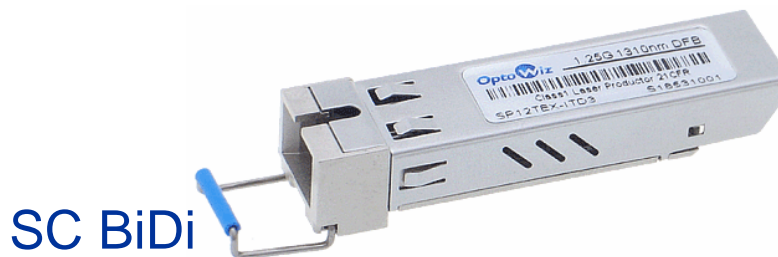

SC BiDi



GBIC



LC BiDi

10 Gbitni vmesniki

SFP+



10GBASE-SR MM 300m
10GBASE-LR SM 10km
10GBASE-ER SM 40km

XFP



XENPAK



X2





40 in 100 Gbitni vmesniki



40/100G CFP, dvojna širina Xenpak-a



QSFP (baker) 40G kabli



CXP, povezave v Data Centrih

elementi

ROSA, Receiver Optical Sub-Assembly

TOSA, Transmitter Optical Sub-Assembly

BOSA, Bidi Optical Sub-Assembly



po enem vlaknu

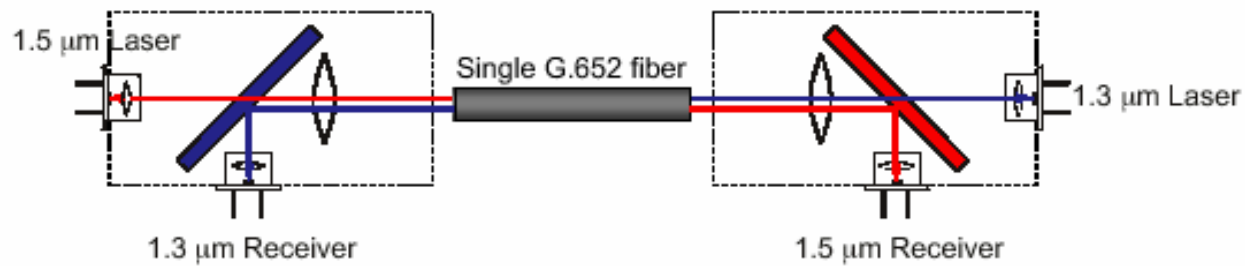

SM uporablja 1310/1550nm

MM uporablja 850/1300nm,

“dichroic beam splitters”

in “wavelength-selective detectors”



POF



1 SFP
8 FE POF (~50m)
2 GbE RJ45



serijski / industrijski pretvorniki

RS232 na MM/SM

RS232/422/485 na MM/SM

IP zaščita, DIN letve, POF, PUR



video pretvorniki

analogni ali digitalni

pretvorniki lahko analogni signal stisnejo in takega prenašajo po vlaknu, ali pa analogni signal spremenijo v digitalnega in ga neposredno prenašajo



telefonski pretvorniki

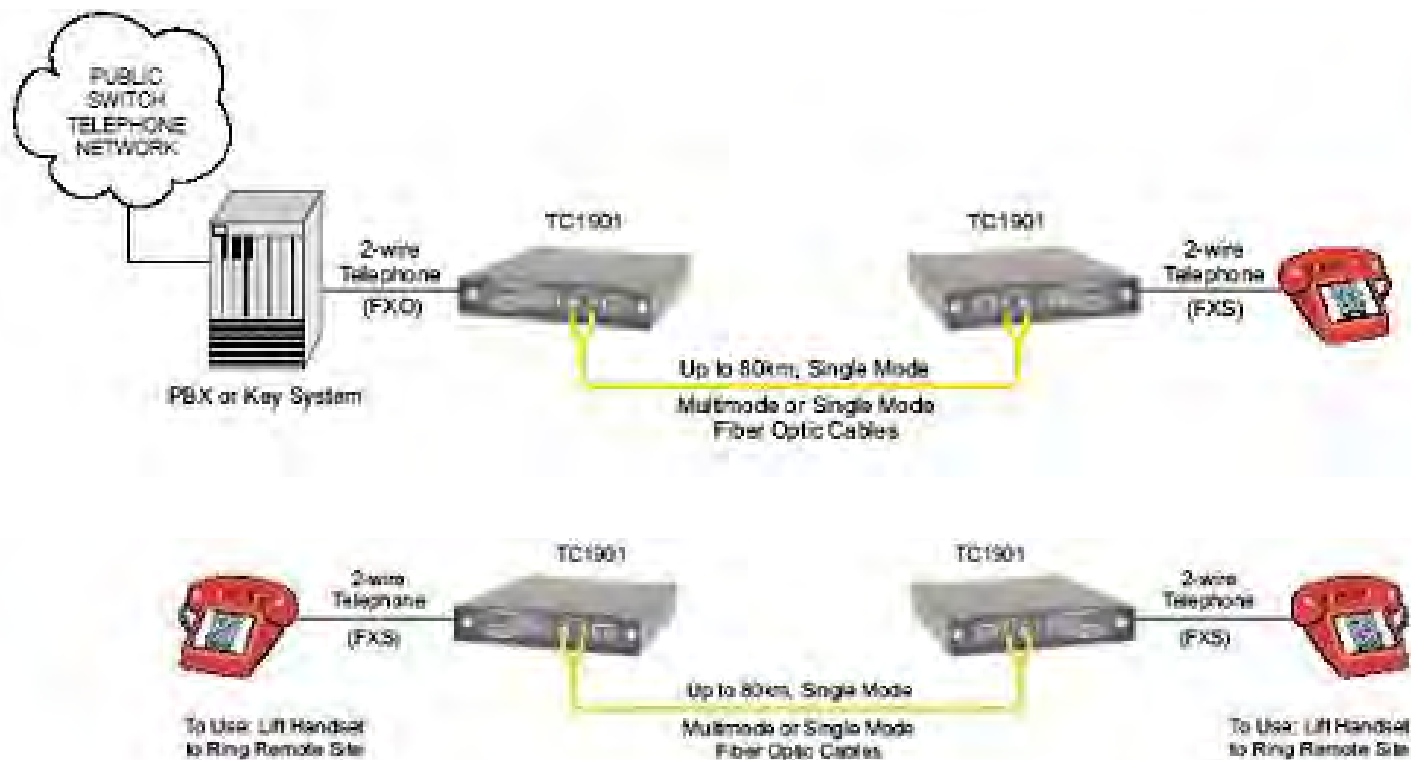

2011 in naprej

Skype je imel konec leta 2010 v povprečju 124 milijonov delujočih uporabnikov na mesec. Več kot 700 milijard minut na mesec porabimo na Facebook-u. Glede na napovedi (Cisco VNI), se bo globalni mobilni promet podatkov med letoma 2010 in 2015 povečal za 26-krat in do leta 2015 dosegel 6,3 eksabajta na mesec.

2011 in naprej

Pričakuje se nadaljevanje razvoja širokopasovnih tehnologij :
40, 100, 400 in 1000-Gb/s (1-Tb/s).

FTTX tehnologije se bodo širile na vsa področja (konec 2010 v ZDA že 20 milijonov povezanih domov). Potreba po širokopasovnem dostopu bo postala globalna. Pravilo odprtega dostopa bo standard. Standardu IEEE 10G EPON se bo pridružil še ITU standard 10G GPON (XG-PON). Testira se že XG-PON1(10-Gb/proti uporabniku) in XG-PON2(10-Gb/s v obe smeri).

Oprema bo manjša po velikosti, energetsko varčna, z nižjo ceno in hkrati bolj zmogljiva. Skratka zelena.

2011 in naprej

Tudi v bodoče bodo uporabniki, razvijalci, ponudniki, .. želeli povečati pasovno širino in zmanjšati stroške. 40-Gb/s se bo po vsej verjetnosti ohranila kot vmesna tehnologija. Pričakuje se povečana uporaba OM3 in OM4 vlakna.

Veliko vprašanje je katera tehnologija bo v prihodnosti prevladala na HDTV področju. Bo to EPON, GPON, ali kakšna druga FTTH tehnologija? Nekateri poznavalci pravijo, da nobena od teh. V ospredju je HFC (Hybrid Fiber/Coax) in DOCSIS (Data Over Cable Service Interface Specification), RFoG (over glass), DPoE (DOCSIS Provisioning of EPON), prava smer se še išče.

(napovedi po reviji LightWave)



hvala za pozornost

info@ezz.si